

Quick Fact Sheet



shop**GURU**

DISCOVER WHY SHOPGURU® IS EVERY CNC MACHINIST'S BEST FRIEND!

shopGURU is the only software designed to empower CNC Machinists of any experience level to independently produce even the most complex parts - on time, every time.

Here are the key features inside shopGURU that turn your CNC Machinists into CNC Gurus!

shopGURU® JOB SETUP

Bulletproof your machining process by easily recording all workholding, tooling, and inspection data or follow previously recorded steps to produce perfect parts from start to finish.

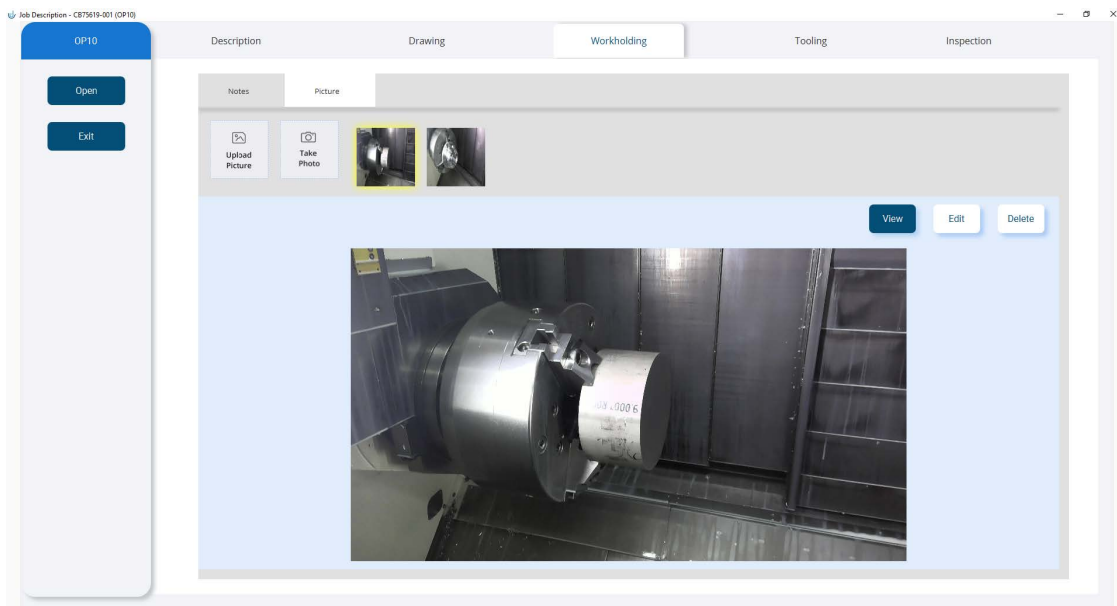
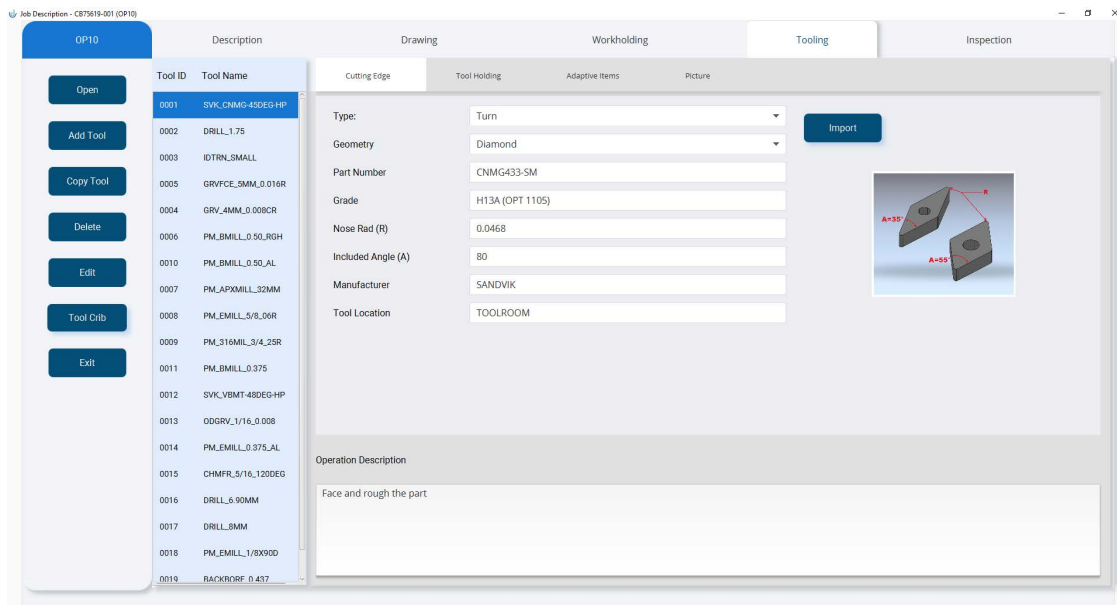

shopGURU® PART INSPECTION

Define each step of in-process inspection to ensure your machinists meet part quality requirements and ensure consistent levels of quality.

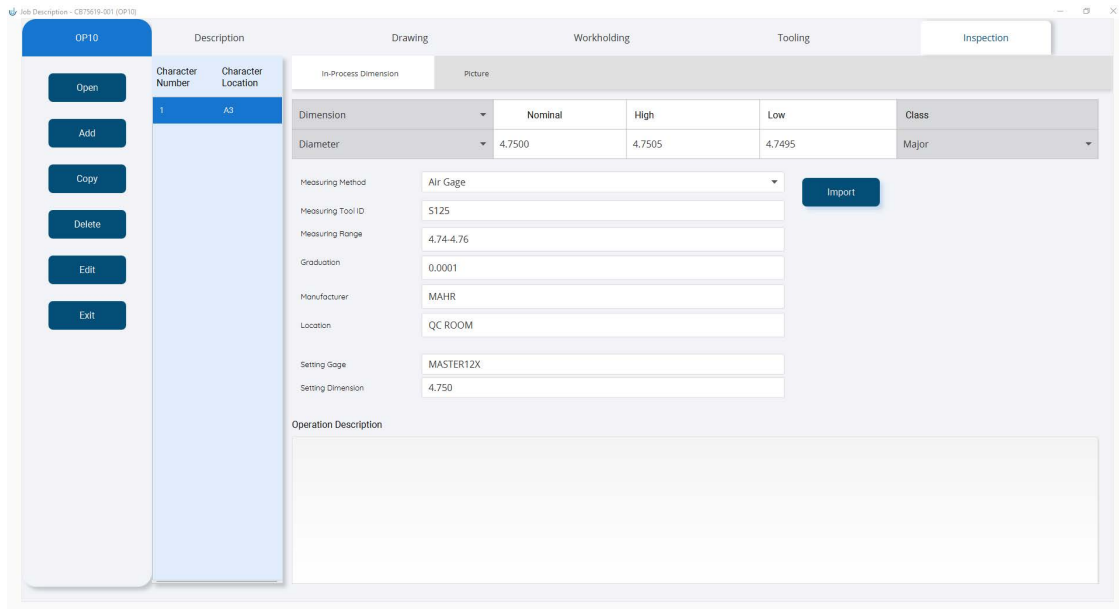

shopGURU® TOOL CRIB

Import and save all of your cutting tools, adaptive items, and measuring tools into your jobs. Avoid costly mistakes, crashes, and tool damages resulting from incorrect tools and holders. 3D models and photos ensure proper tooling selections.

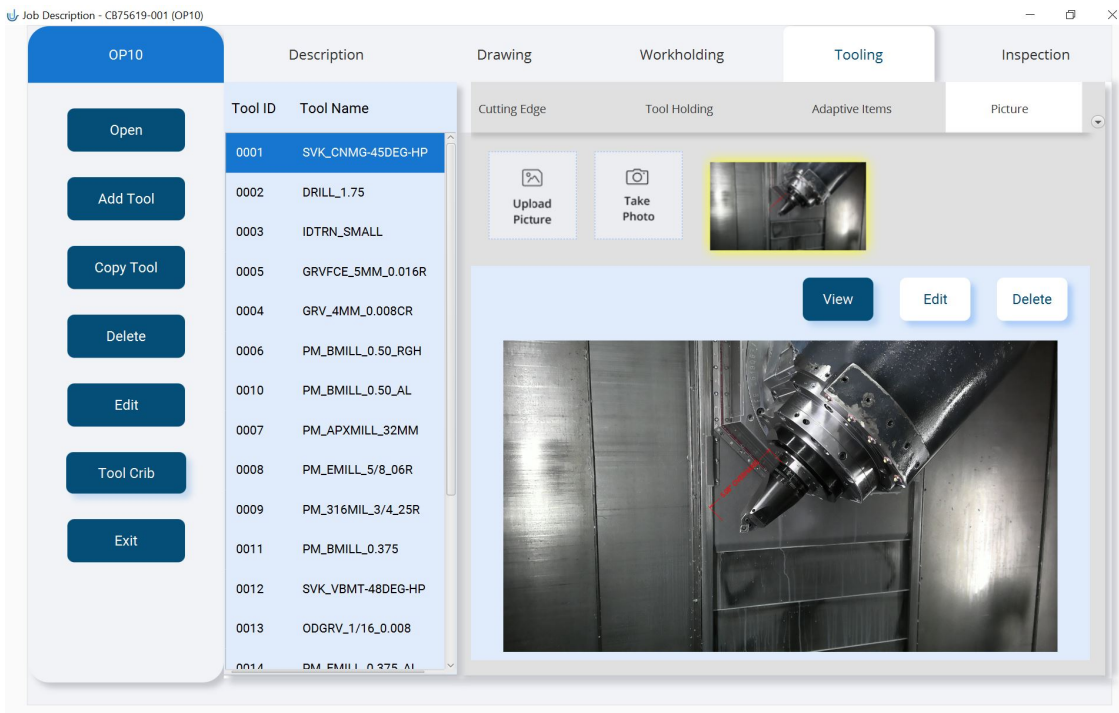

VIEW PART DRAWINGS AND 3D MODELS

Import part drawings and 3D models to provide your machinists with ultimate part visibility and confidence to get the job done right. This also ensures your machinists are using the proper part revision.

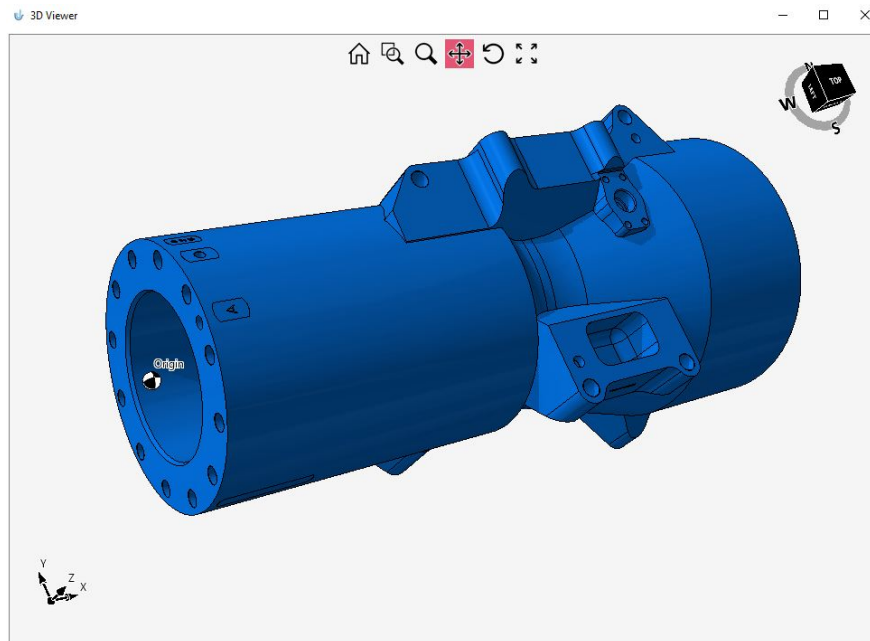

TAKE PICTURES

Take pictures of your entire setup, workholding, and tooling with your mobile tablet right at the machine. Recall pictures later for accurate production every time.

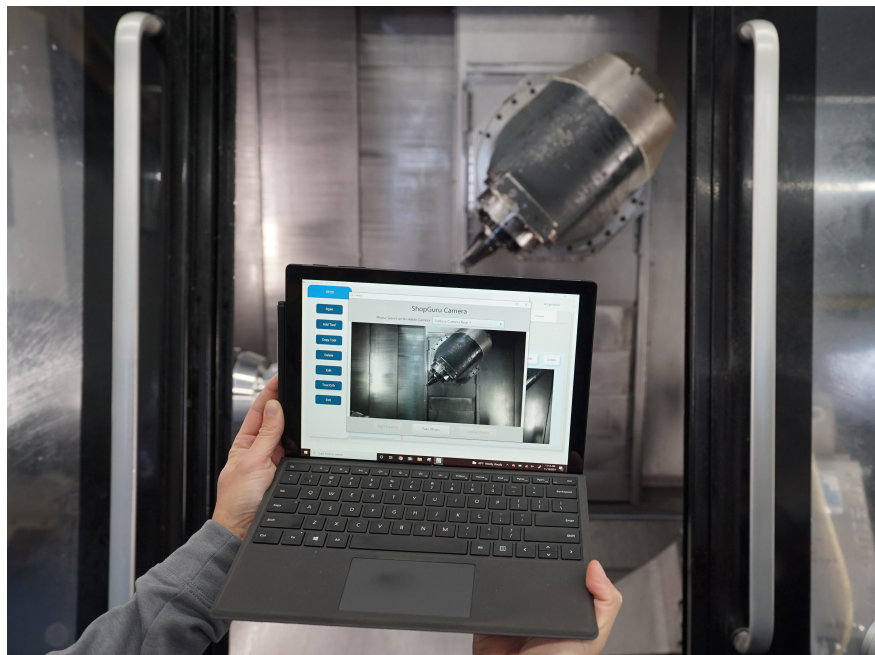

CREATE MARKUPS & KEEP NOTES

When you import or take pictures with your shopGURU® camera, you can easily create markups with key dimensions, notes, and more to ensure no detail is missed. Keep important job-specific notes such as tool life, troubleshooting notes, and more.

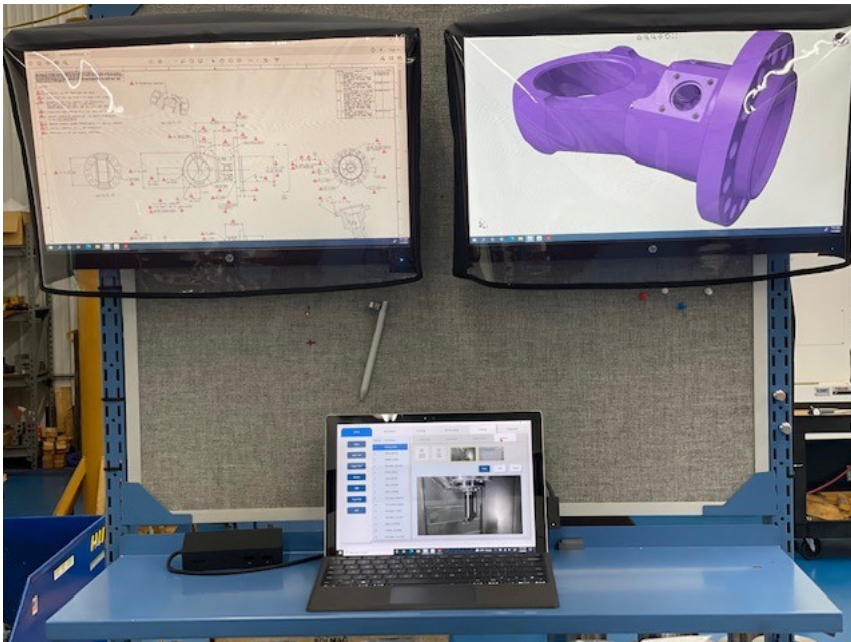

shopGURU® USER ROLES

shopGURU® user roles can be defined by machinist experience level including operators with read only access, job creators who create new jobs and edit data, and administrators with full access.

shopGURU® DATA

shopGURU® job data is automatically saved. Eliminate worries about machinists forgetting to save data and protect your information in case of computer crashes, device failures, or power outages. Unused data or photos can be easily cleaned up to optimize performance.

shopGURU® clients have reported drastic results

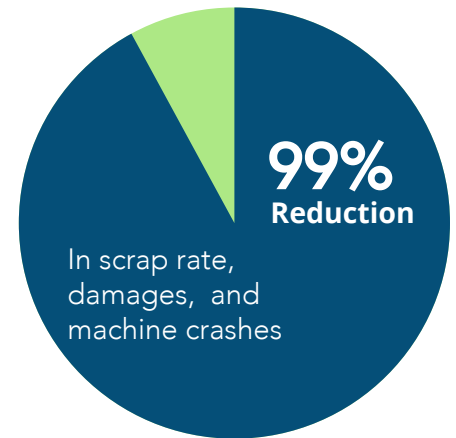
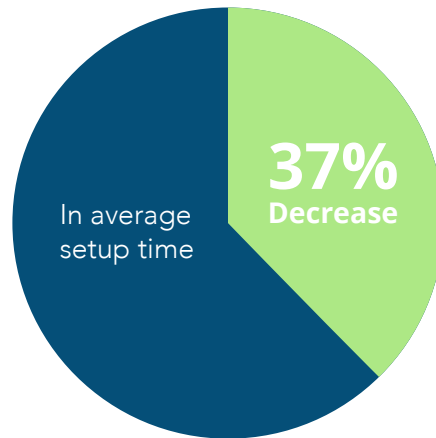
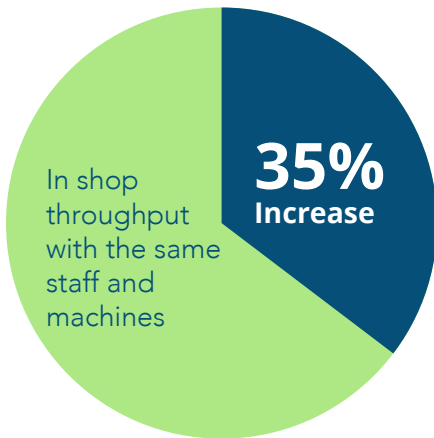

ALL YOU NEED IS A LICENSE TO THE BEST CNC SETUP SOFTWARE

To get started with shopGURU®, all you need is a license for your business. Licenses are available with any number of seats to accommodate your entire team.

Go to www.cncshopguru.com/demo to book a free, private demo today!

 shopGURU.com

 1975 Wehrle Drive Williamsville, NY 14221

 support@cncshopguru.com

